

THIS DRAWING IS UNPUBLISHED. RELEASED FOR PUBLICATION
 © COPYRIGHT BY TYCO ELECTRONICS CORPORATION. ALL RIGHTS RESERVED.

LOC	DIST	REVISIONS					
DF	DO	P	LTR	DESCRIPTION	DATE	DWN	APVD
		P		REV PER ECO 07-023891	10-16-07	CT	BW

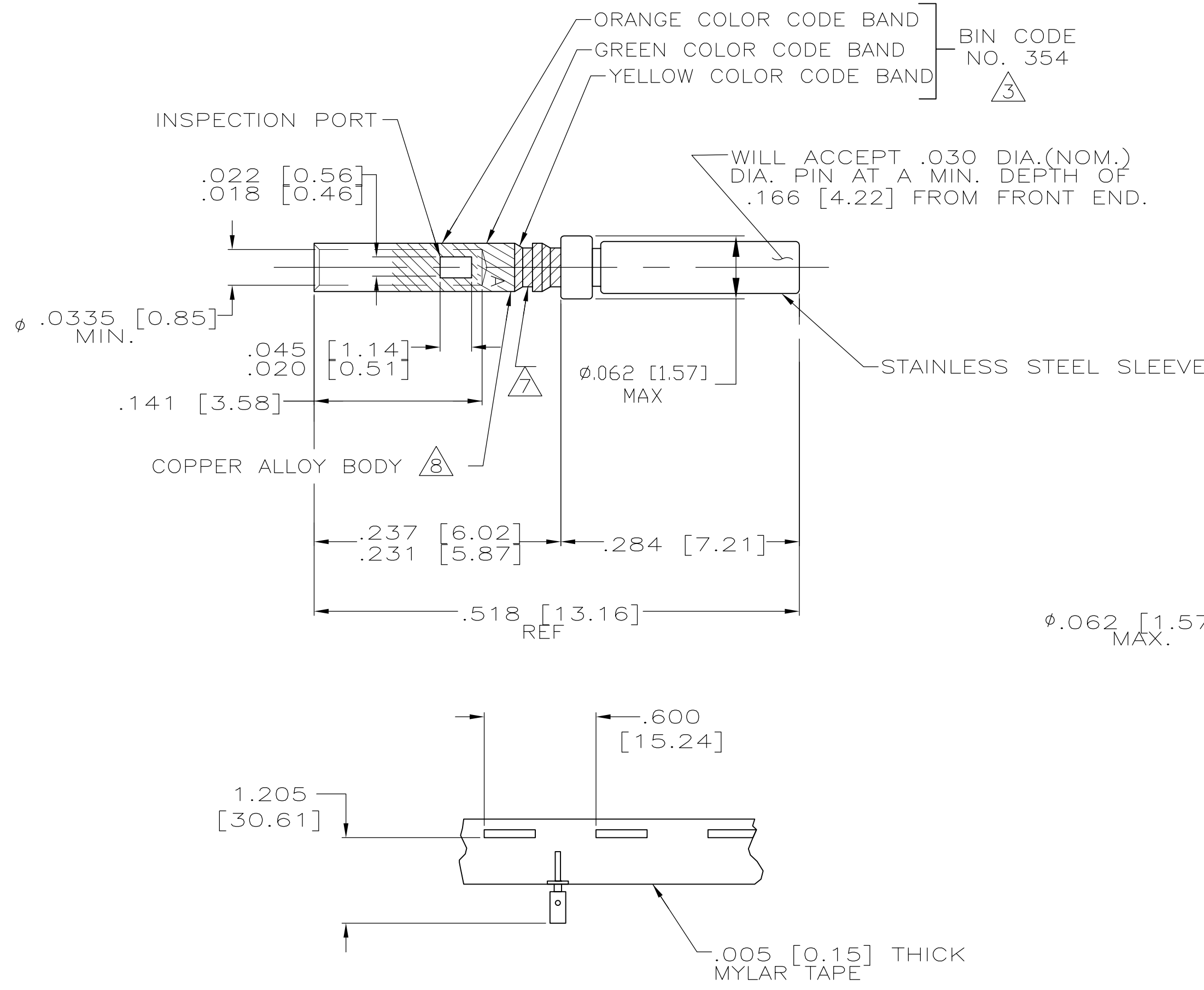

1. WIRE BARREL WILL ACCEPT #22-28 AWG WIRE.
2. CRIMPING TOOL- USE MS3198-1 WITH APPLICABLE POSITIONER.
3. CONTACT CONFORMS TO MIL-C-39029/57, SIZE 22.
4. NET WEIGHT- .102 GRAMS.
5. INSERTION, EXTRACTION TOOL- AMP P/N 91067-1.
6. THIS CONTACT IDENTIFIED AS MS27491-22 SUPERSEDES M24308/12-1.
7. IDENTIFICATION GROOVE IS OPTIONAL.
8. PLATING: GOLD PER MIL-G-45204 OVER NICKEL.

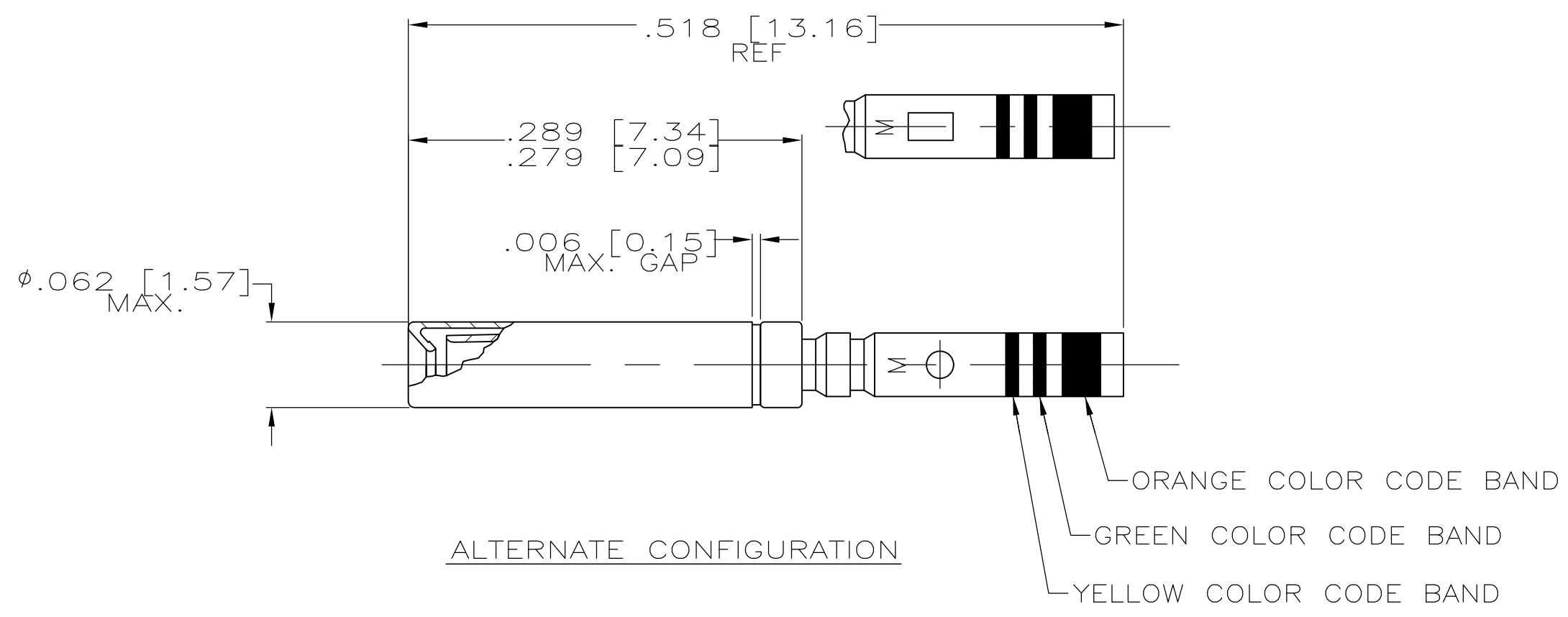

WHEN ORDERING CONTACT ON TAPE, ORDER BY THE TAPE NUMBER PLUS THE PACKAGING CODE AS FOLLOWS:

2. FOR USE WITH AMP TAPETRONIC, PNEUMATIC TOOL-
A. 1000 PARTS TO A BOX ADD PACKAGING CODE: 1MBOX
3. FOR USE WITH 4/8 INDENT STRIPPER CRIMPER-
A. 1000 PARTS TO A REEL ADD PACKAGING CODE: 1MREEL
B. 5000 PARTS TO A REEL ADD PACKAGING CODE: 5MREEL

AS SHOWN; NO COLOR CODE	8	204351-4
CONTACTS ON TAPE; COLOR CODED	8	204351-2
AS SHOWN; COLOR CODED	8	204351-1
DESCRIPTION	PLATING	PART NO.

THIS DRAWING IS A CONTROLLED DOCUMENT.		DWN R. RINEHART 10-5-90	Tyco Electronics Corporation Harrisburg, PA 17105-3608	
DIMENSIONS: INCHES [mm]		CHK R.GILLIMAN 10-10-90	NAME CONTACT ASS'Y, SOCKET SIZE 22D, AMPLIMITE	
TOLERANCES UNLESS OTHERWISE SPECIFIED:		APVD R.GILLIMAN 10-10-90	PRODUCT SPEC	
0 PLC ± -		APPLICATION SPEC		
1 PLC ± -		-		
2 PLC ± -		-		
3 PLC ± .005 [0.13]		-		
4 PLC ± -		-		
ANGLES ± -		-		
FINISH		WEIGHT .102 GRAMS		
-		CUSTOMER DRAWING		
		SCALE 10:1	SHEET 1 of 1	REV P